

Type	: High Temperature Rechargeable Nickel Cadmium Cylindrical Cell	
Nominal Dimension (with Sleeve)	: $\phi=25.7\text{mm}$ H =50.0mm	
Applications	: Permanent charging and standby application	
Nominal Voltage	: 1.2V	
Capacity	: Minimum: 2500mAh Typical: 2625mAh When discharged at 500mA to 1.0V at 20	
Charging Condition	: 250mA for 14 hrs at 20	
Service Life	: > 500 cycles (IEC61951 standard)	
Continuous Overcharge	: Comply with IEC61951 Permanent Charge Endurance Test	
Weight (approximate)	: 70g	
Internal Resistance	: Average 10m upon fully charged At 1000Hz	
Charge Retention	: 70% (IEC standard)	
Ambient Temperature Range	Standard Charging	: 0 to 70
	Discharging	: - 20 to 70
	Storage	: - 20 to 35
	Storage (1 week)	: - 20 to 60

Low Rate Discharge

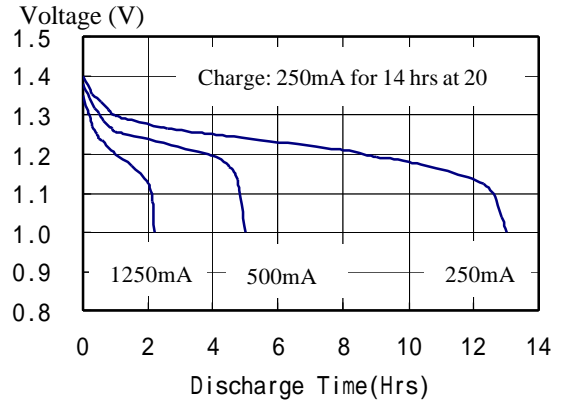

High Rate Discharge

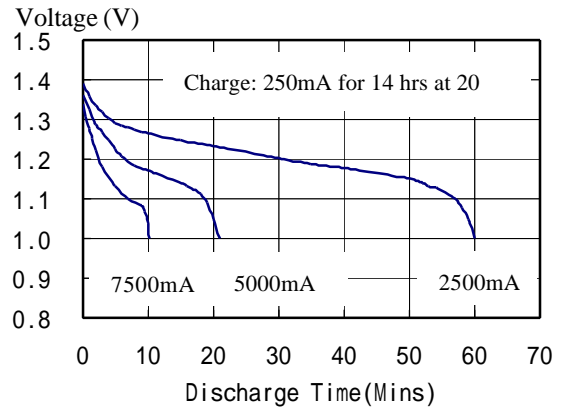

Charge/discharge efficiency vs. temp.

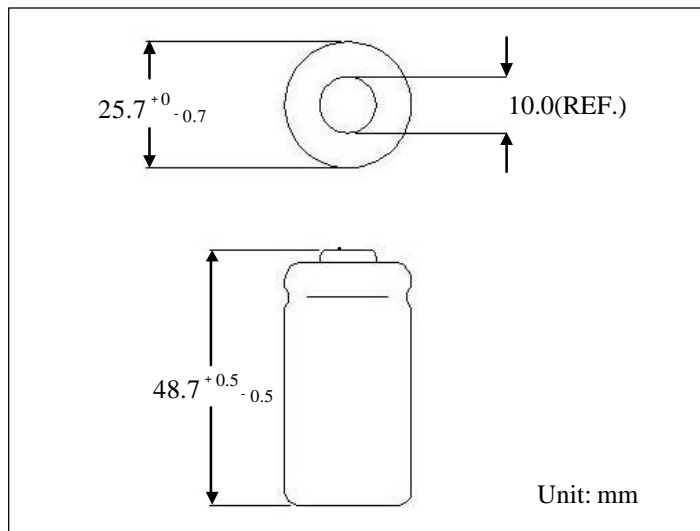
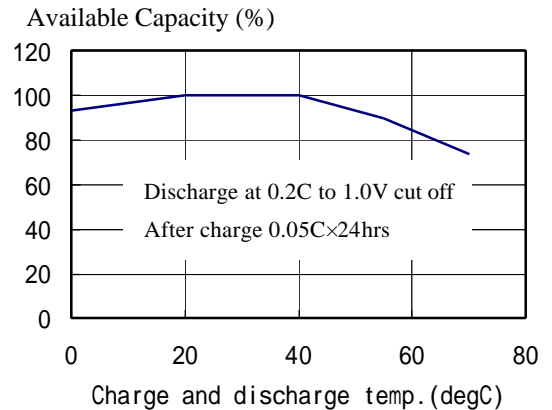

Unit: mm

* The information contained in this document is for reference only and should not be used as a basis for product guarantee or warranty. For applications other than those described here, please consult C-POWER.

Note: All the above values subject to change without prior notice.